

CONDITII TEHNICE

- Tolerante ISO 2768 - mK
- Muchiile ascute neindicate se vor tesii cu 0,5x45°
- Material conf. compozitiei chimice prezentate de beneficiar :
- O2 (ANSI) <=> T31502 (UNS) <=> W1.2842

Compozitia chimica

- Fe = 97,42 %
- Mn = 1,79 %
- Si = 0,37 %
- Cr = 0,34 %
- V = 0,08 %

33
// //

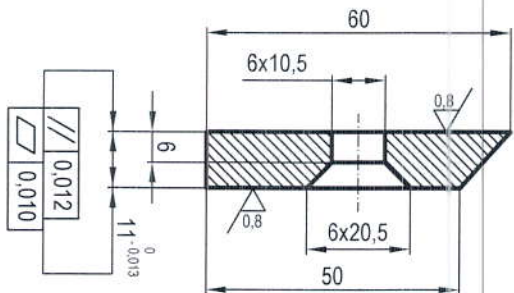

C-C

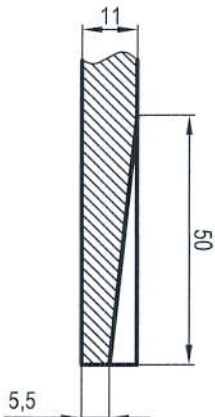

TURBOCOM E. C.

Beneficiar : S.C. PETROTEL LUKOIL S.A.

Aria : 4

Scara

BRATI STANGA SPATE + DREAPTA FATA

Nr. proiect :	T 0132 - 00/BD	Nr. desen :	T 0132 - 01	Rev.
Orig. desen		Material	*	

Nr. rev.	Denumirea modificarii	Data	Proiectat	Desenat	Aprobat
00	Prima editie	17.05.2019	Ion Ene	Ion Ene	Ing. G. Popescu
01					
02					
03					
04					



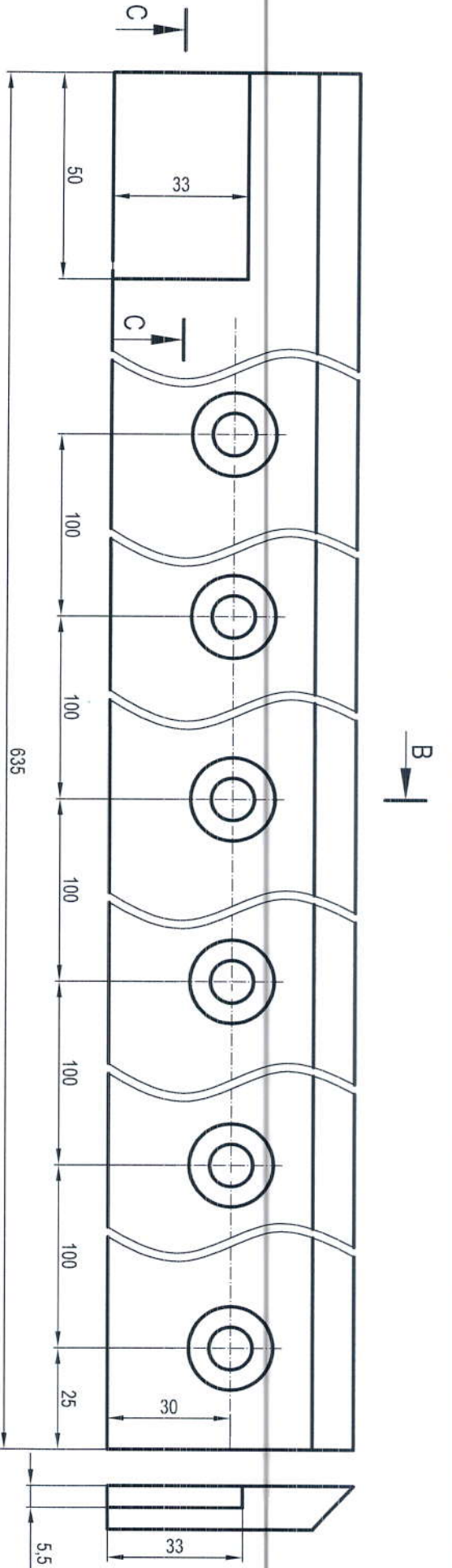

CONDITII TEHNICE

- Tolerante ISO 2768 - mK
- Muchiile ascute neindicate se vor tasi cu 0,5x45°
- * - Material conf. compozitiei chimice prezentate de beneficiar : O2 (AISI) <=> T31502 (UNS) <=> W1.2842

Compozitia chimica

- Fe = 97,42 %
- Mn = 1,79 %
- Si = 0,37 %
- Cr = 0,34 %
- V = 0,08 %

B - B

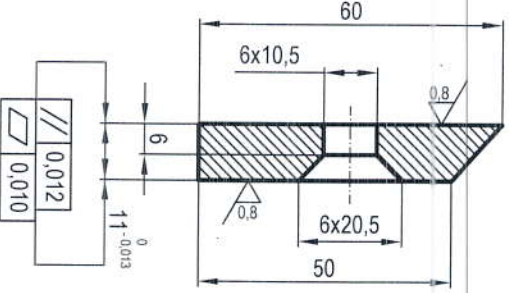

C - C

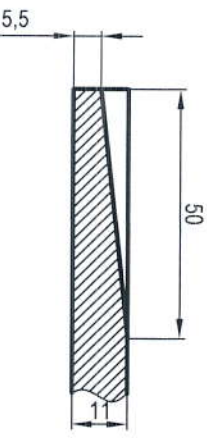

TURBOCOM E. C.

Beneficiar : S.C. PETROTEL LUKOIL S.A.		Nr. proiect :		Nr. desen :		Rev.	
Aria : 4		T 0132 - 00/BD		T 0132 - 02			
Instalata : Rampa Automata		Orig. desen		Material		*	

Nr. rev.	Denumirea modificarii	Data	Proiectat	Desenat	Aprobat
00	Prima editie	17.05.2019	Ion Fine	Ion Fine	Ing. G. Popescu
01					
02					
03					
04					

Scara	Denumire desen	Utilaj
1:1	BRAT STANGA FATA + DREAPTA SPATE	Carucior fir nr. 4



